



Piper Aircraft, Inc.
2926 Piper Drive
Vero Beach, Florida, U.S.A. 32960

SERVICE BULLETIN

NO. 1242

PIPER CONSIDERS COMPLIANCE MANDATORY

Date: January 30, 2015

(S) (M)

Service Bulletin (SB) 1242 supersedes Service Letter (SL) 671 in its entirety. Aircraft that have previously complied with SL 671 must still comply with SB 1242, Part I.

SUBJECT:

RUDDER PEDAL ASSEMBLY INSPECTION

MODELS AFFECTED:

PA-28-140 Cherokee
PA-28-150/-160 Cherokee
PA-28-180 Cherokee

PA-28S-160 Cherokee
PA-28S-180 Cherokee
PA-28-235 Cherokee Pathfinder

PA-28-236 Dakota
PA-28-151 Warrior
PA-28-161 Cadet
PA-28-161 Warrior II

PA-28-161 Warrior III
PA-28-180 Archer
PA-28-181 Archer II

PA-28-181 Archer III
PA-28-201T Turbo Dakota
PA-28R-180 Arrow

PA-28R-200 Arrow

PA-28R-200 Arrow II
PA-28R-201 Arrow III

PA-28R-201T Turbo Arrow III

PA-28RT-201 Arrow IV
PA-28RT-201T Turbo Arrow IV

SERIAL NUMBERS AFFECTED:

28-20001 thru 28-26946; 28-7125001 thru 28-7725290
28-03; 28-1 thru 28-4377; 28-1760A
28-03; 28-671 thru 28-5859;
28-7105001 thru 28-7205318
28-1 thru 28-1760; 28-1760A
28-671 thru 28-5859; 28-7105001 thru 28-7105234
28E-11; 28-10001 thru 28-11378;
28-7110001 thru 28-7710089
28-7911001 thru 28-8611008; 2811001 thru 2811050
28-7415001 thru 28-7715314
2841001 thru 2841365
28-7716001 thru 28-8216300;
28-8316001 thru 28-8616057; 2816001 thru 2816109
2816110 thru 2816119; 2842001 and up
28-E13; 28-7305001 thru 28-7505260
28-7690001 thru 28-8690056; 28-8690061,
28-8690062; 2890001 thru 2890205
2890206 thru 2890231; 2843001 and up
28-7921001 thru 28-7921095
28R-30002 thru 28R-31270;
28R-7130001 thru 28R-7130013
28R-35001 thru 28R-35820;
28R-7135001 thru 28R-7135229
28R-7235001 thru 28R-7635545
28R-7737002 thru 28R-7837317;
2837001 thru 2837061; 2844001 and up
28R-7703001 thru 28R-7803374;
2803001 thru 2803012
28R-7918001 thru 28R-8218026
28R-7931001 thru 28R-8631005; 2831001 thru 2831038

ATA: 2710

(OVER)

PA-32-260 Cherokee Six	32-03; 32-04; 32-1 thru 32-1297; 32-7100001 thru 32-7800008
PA-32-300 Cherokee Six	32-15; 32-21; 32-40000 thru 32-40974; 32-7140001 thru 32-7940290
PA-32S-300 Cherokee Six Seaplane	32S-15; 32S-40000 thru 32S-40974; 32S-7140001 thru 32S-7240137
PA-32R-300 Lance	32R-7680001 thru 32R-7880068
PA-32RT-300 Lance II	32R-7885002 thru 32R-7985106
PA-32RT-300T Turbo Lance II	32R-7787001; 32R-7887002 thru 32R-7987126
PA-32R-301 Saratoga SP	32R-8013001 thru 32R-8613006; 3213001 thru 3213028; 3213030 thru 3213041
PA-32R-301 Saratoga II HP	3213029; 3213042 thru 3213103; 3246001 thru 3246244
PA-32R-301T Turbo Saratoga SP	32R-8029001 thru 32R-8629008; 3229001 thru 3229003
PA-32-301 Saratoga	32-8006002 thru 32-8606023; 3206001 thru 3206019; 3206042 thru 3206044; 3206047; 3206050 thru 3206055; 3206060
PA-32-301T Turbo Saratoga	32-8024001 thru 32-8424002
PA-32R-301T Saratoga II TC	3257001 thru 3257483
PA-32-301FT Piper 6X	3232001 thru 3232074
PA-32-301XTC Piper 6XT	3255001 thru 3255027; 3255051
PA-34-200 Seneca	34-E4; 34-7250001 thru 34-7450220
PA-34-200T Seneca II	34-7570001 thru 34-8170092
PA-34-220T Seneca III	34-8133001 thru 34-8633031; 3433001 thru 3433172; 3448001 thru 3448037
PA-34-220T Seneca IV	3448038 thru 3448079; 3447001 thru 3447029
PA-34-220T Seneca V	3449001 and up
PA-44-180 Seminole	44-7995001 thru 44-8195026; 4495001 thru 4495013; 4496001 and up
PA-44-180T Seminole	44-8107001 thru 44-8207020

COMPLIANCE TIME:

For airplanes with 1,200 hours or more time in service, initial inspection to occur at the next regularly scheduled maintenance event, not to exceed the next 100 hours time in service. Thereafter, a recurring inspection shall take place every 100 hours time in service.

Installation of a new pedal and bar assembly and, if applicable, a new rudder bar support assembly will relieve this recurring inspection requirement, until the new components reach 1,200 hours time in service.

APPROVAL:

The engineering aspects of this service document have been shown to comply with the applicable Federal Aviation Regulations and are FAA approved.

PURPOSE:

A review of the service history on the affected airplanes reveals that, over time, cracks may develop in specific locations on the pedal and bar assembly and the rudder bar support assembly. This service bulletin provides a schedule and instructions for the inspection of these critical components for cracks, and for modification or replacement, on condition.

INSTRUCTIONS:**Part I. Modification**

Part I is applicable to the following airplanes only:

PA-28-140 Cherokee	28-20001 thru 28-7325073
PA-28-150/-160/-180 Cherokee	28-03, 28-1 thru 28-7305081
PA-28-235 Cherokee Pathfinder	28-10001 thru 28-7310048
PA-28R-180 Arrow	28R-30002 thru 28R-7130013
PA-28R-200 Arrow	28R-35001 thru 28R-35820; 28R-7135001 thru 28R-7135229
PA-28R-200 Arrow II	28R-7235001 thru 28R-7335089
PA-32-260 Cherokee Six	32-03, 32-04, 32-1 thru 32-7300011
PA-32-300 Cherokee Six	32-15, 32-21, 32-40000 thru 32-7340054
PA-34-200 Seneca	34-E4, 34-7250001 thru 34-7350129

- Examine the area identified in Figures 1 and 2 to determine which rudder bar assembly configuration is installed on the airplane.
 - If the rudder bar assembly conforms to Figure 2, Detail B, the airplane is already in compliance with Service Letter (SL) 671, and/or a replacement rudder bar assembly has been installed which includes these features. No modification is required. Proceed to Part II.
 - If the rudder bar assembly conforms to Figure 2, Detail A, modification is required. Proceed to Step 2, below.

NOTE: All new replacement rudder bar assemblies conform to the configuration shown in Detail B. At the operator's discretion, a new replacement rudder bar assembly may be installed in lieu of the modification described below.

- Remove the rudder bar assembly from the airplane and disassemble.

NOTE: Removing and reinstalling the rudder bar assembly from the aircraft will require disconnecting, reinstalling, and rigging of flight control, braking, and steering systems. Refer to the appropriate sections or chapters of the applicable Piper maintenance manual for specific instructions for each system, as well as the required installation torque for threaded fasteners. Strip the area to be modified using a commercially available chemical paint stripper, such as Cee-Bee E-2012 or E-2060 paint stripper.

- Examine the area to be modified for cracks, using the inspection criteria described in Part II. Any cracked components must be replaced prior to proceeding.
- Order one each of Piper part numbers (P/N) 99938-000 and 99938-001 rudder bar straps. TIG weld in place as shown in Detail B, per Chapter 4 of AC 43.13-1B (or latest revision). After welding, relieve residual stress in the affected area: Heat with a non-carburizing torch flame to 1,000°–1,100° F (538°–593° C) (a brown red color) then air cool to room temperature. All welding must be performed by a certified welder.

NOTE: Installation of the rudder bar straps does not relieve the requirement for the recurring inspection in Part II.

NOTE: The following information will assist in the modification:

- All materials are 4130 normalized steel.
- The rudder bar tubes have a nominal outside diameter of 0.875 inches and nominal wall thickness of 0.058 inches.
- P/N 99938-000 and 99938-001 rudder bar straps are made from sheet steel with a nominal thickness of 0.040 inches.

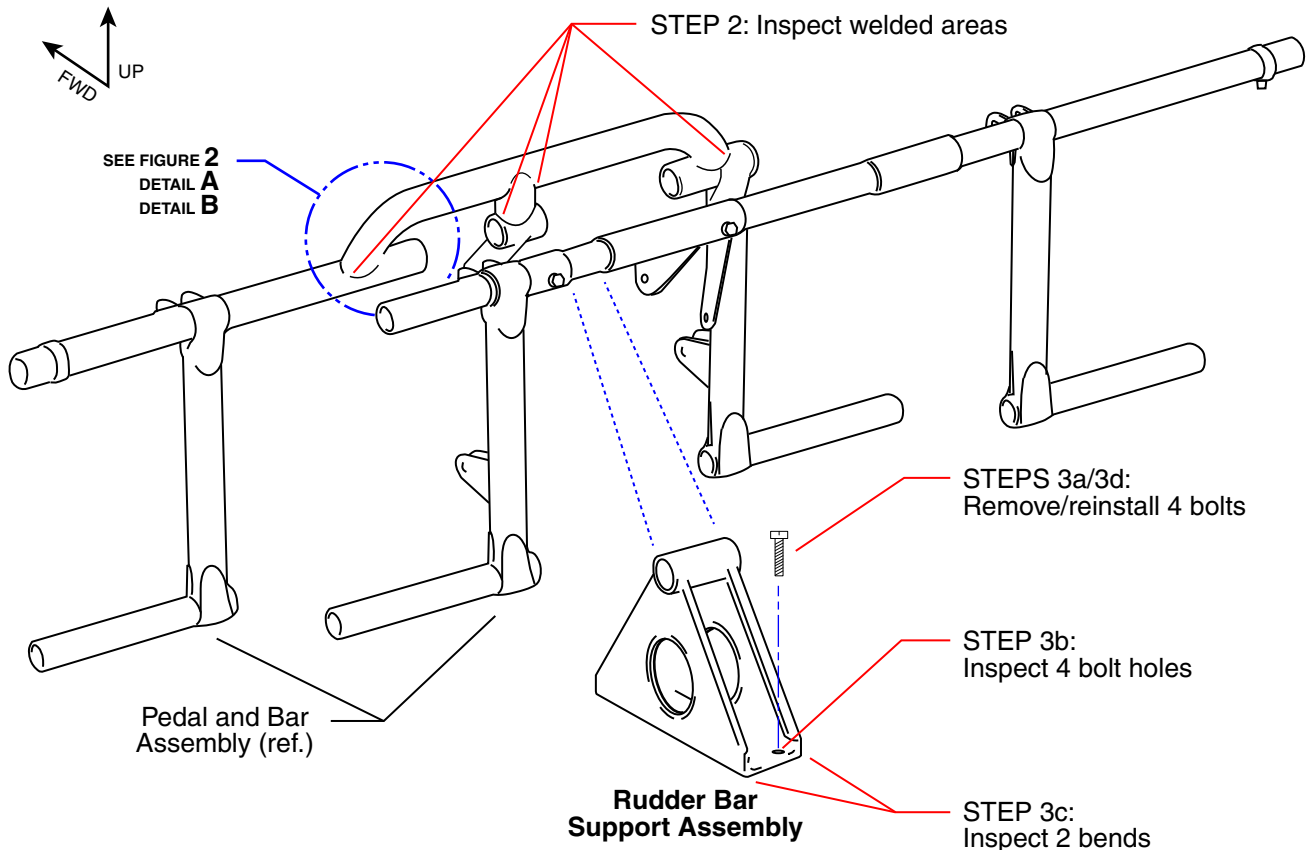

Figure 1
Rudder Pedal Installation (Typical)

5. Descal, degrease and repaint the bare steel on the rudder bar assembly using epoxy primer (two coats) and a topcoat of matching black color.
6. Reassemble the rudder bar and reinstall into the airplane.
7. Make a logbook entry documenting compliance with Part I of this service bulletin.

Part II. Inspection

NOTE: Temporary removal of interior components may be required in order to accomplish the instructions that follow.

1. Gain access to the areas identified in Figure 1.

NOTE: The inspections described in this service bulletin shall be accomplished using a 10X magnifier, a mirror and a suitable light source or other equipment capable of providing equal or better resolution.

NOTE: Any cracked components must be replaced prior to next flight.

2. Pedal and Bar Assembly Inspection

Visually inspect all welds, with specific emphasis on the locations identified in Figure 1.

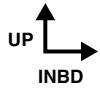

RUDDER BAR ASSEMBLY

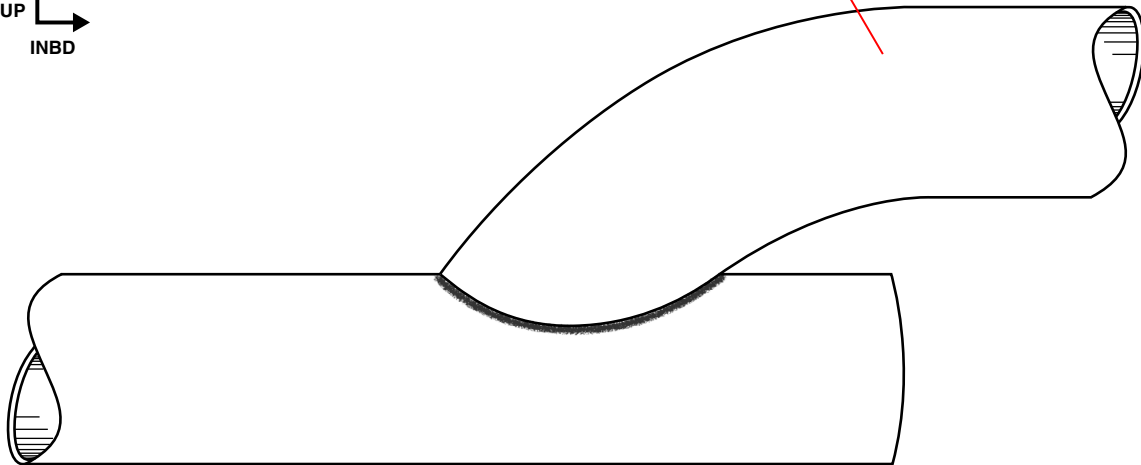

DETAIL A

RUDDER BAR ASSEMBLY

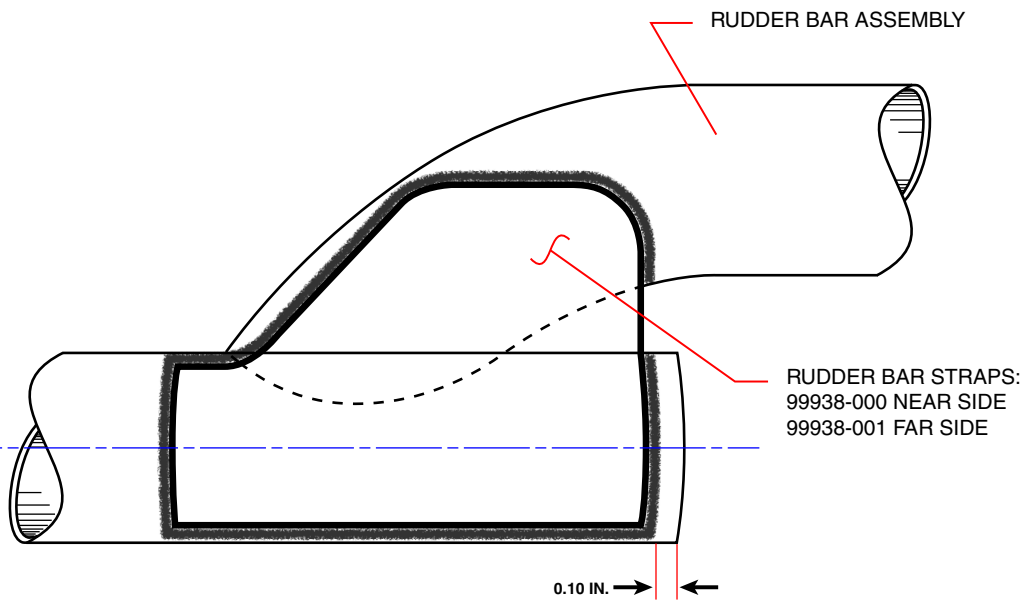
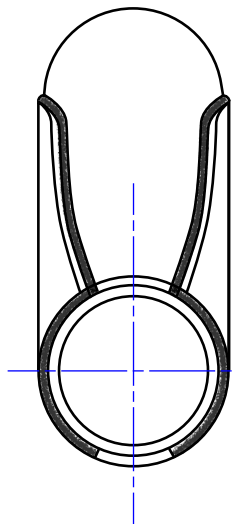

DETAIL B

Figure 2
Rudder Bar Welding (Typical)

3. Rudder Bar Support Assembly Inspection

NOTE: The inspection described in Step 3 is applicable only to the following airplane models:

- PA-28 series, fixed gear models only
- PA-32 series, both fixed gear and retractable gear models
- PA-44 series

The retractable gear PA-28R series and the PA-34 series models use a different type of rudder bar support assembly, which does not have a service history of cracking.

- a. Remove and retain the four (4) bolts that secure the rudder bar support assembly to the cockpit floor.

NOTE: It is not necessary to remove the rudder bar support assembly to accomplish this inspection.

- b. Visually inspect the four (4) bolt holes for cracks and elongation. See Figure 1. The diameter of the four bolt holes should measure 0.250 +0.005/-0.001 inches.
- c. Visually inspect the two (2) sheet metal bends common to the base for cracking, the entire length of each bend, both inner and outer surfaces. See Figure 1.
- d. Reinstall the four (4) bolts that secure the rudder bar support assembly to the cockpit floor. Refer to the appropriate section or chapter of the applicable Piper maintenance manual for the required installation torque for threaded fasteners.

4. Make a logbook entry documenting compliance with this service bulletin, until the next inspection interval is reached per Compliance Time, above.

MATERIAL REQUIRED:

Part I: One each, on condition as determined by inspection, P/N 99938-000 and 99938-001 rudder bar straps, per affected airplane

Part II: Rudder pedal assembly components, on condition as determined by inspection (see applicable parts catalog)

AVAILABILITY OF PARTS:

Your Factory Authorized Piper Service Facility

EFFECTIVITY DATE:

This service bulletin is effective upon receipt.

SUMMARY:

Please contact your Factory Authorized Piper Service Facility to make arrangements for compliance with this service bulletin in accordance with the compliance time indicated.

NOTE: Please notify the factory of any address/ownership corrections. Changes should include aircraft model, serial number, and current owner's name and address.

Corrections and/or changes should be directed to:

PIPER AIRCRAFT, INC.
Attn: Customer Service
2926 Piper Drive
Vero Beach, FL 32960