



**Piper Aircraft, Inc.**  
2926 Piper Drive  
Vero Beach, Florida, U.S.A. 32960

# SERVICE NO. 1197D

# BULLETIN

## PIPER CONSIDERS COMPLIANCE MANDATORY

Date: February 25, 2011

(S) (M)

SB 1197D supersedes SB 1197C. SB 1197D adds Table 4 to eliminate confusion in acceptable part numbers.

Aircraft that have previously complied with SB 1197, SB 1197A, SB 1197B and SB 1197C are in compliance with SB 1197D.

**SUBJECT:**

**CONTROL WHEEL SHAFT INSPECTION**

**MODELS AFFECTED:**

PA-28-140 Cherokee Cruiser

PA-28-150 Cherokee  
PA-28-160 Cherokee  
PA-28-180 Cherokee

PA-28S-160 Cherokee  
PA-28S-180 Cherokee

PA-28-235 Cherokee Pathfinder

PA-28-235 Cherokee Pathfinder  
PA-28-236 Dakota

PA-28-151 Warrior  
PA-28-161 Cadet  
PA-28-161 Warrior II

PA-28-161 Warrior III  
PA-28-180 Archer  
PA-28-181 Archer II

PA-28-181 Archer III  
PA-28-201T Turbo Dakota  
PA-28R-180 Arrow

PA-28R-200 Arrow

PA-28R-200 Arrow II  
PA-28R-201 Arrow III

PA-28R-201T Turbo Arrow III

PA-28RT-201 Arrow IV  
PA-28RT-201 Arrow IV

**SERIAL NUMBERS AFFECTED:**

28-20001 through 28-26946;  
28-7125001 through 28-7725290  
28-03; 28-1 through 28-4377 and 28-1760A  
28-03; 28-1 through 28-4377 and 28-1760A  
28-03; 28-671 through 28-5859;  
28-7105001 through 28-7205318  
28-1 through 28-1760 and 28-1760A  
28-671 through 28-5859;  
28-7105001 through 28-7105234  
28-10001 through 28-11378;  
28-7110001 through 28-7210023  
28E-11; 28-7310001 through 28-7710089  
28-7911001 through 28-8611008;  
2811001 through 2811050  
28-7415001 through 28-7715314  
2841001 through 2841365  
28-7716001 through 28-8216300; 28-8316001 through  
28-8616057; 2816001 through 2816109  
2816110 through 2816119; 2842001 through 2842305  
28-E13; 28-7305001 through 28-7505260  
28-7690001 through 28-8690056; 28-8690061;  
28-8690062; 2890001 through 2890205  
2890206 through 2890231; 2843001 through 2843672  
28-7921001 through 28-7921095  
28R-30002 through 28R-31270;  
28R-7130001 through 28R-7130013  
28R-35001 through 28R-35820;  
28R-7135001 through 28R-7135229  
28R-7235001 through 28R-7635545  
28R-7737002 through 28R-7837317;  
2837001 through 2837061; 2844001 through 2844138  
28R-7703001 through 28R-7803374;  
2803001 through 2803012  
28R-7918001 through 28R-7918267  
28R-8018001 through 28R-8218026

(OVER)

ATA: 2710

**MODELS AFFECTED:** (Continued)

PA-28RT-201T Turbo Arrow IV

PA-32-260 Cherokee Six

PA-32-300 Cherokee Six

PA-32S-300 Cherokee Six Seaplane

PA-32R-300 Lance

PA-32RT-300 Lance II

PA-32RT-300T Turbo Lance II

PA-32R-301 Saratoga SP

PA-32R-301 Saratoga II HP

PA-32R-301 Saratoga II HP (with Entegra)

PA-32R-301T Turbo Saratoga SP

PA-32-301 Saratoga

PA-32-301T Turbo Saratoga

PA-32R-301T Saratoga II TC

PA-32-301FT Piper 6X

PA-32-301XTC Piper 6XT

PA-32-301XTC Piper 6XT (with Entegra)

PA-34-200 Seneca

PA-34-200T Seneca II

PA-34-220T Seneca III

PA-34-220T Seneca IV

PA-34-220T Seneca V

PA-44-180 Seminole

PA-44-180 Seminole

PA-44-180T Seminole

**SERIAL NUMBERS AFFECTED:** (Continued)28R-7931001 through 28R-8631005;  
2831001 through 283103832-03; 32-04; 32-1 through 32-1297;  
32-7100001 through 32-780000832-15; 32-21; 32-40000 through 32-40974;  
32-7140001 through 32-794029032S-15; 32S-40000 through 32S-40974;  
32S-7140001 through 32S-7240137

32R-7680001 through 32R-7880068

32R-7885002 through 32R-7985106

32R-7787001; 32R-7887002 through 32R-7987126

32R-8013001 through 32R-8613006;

3213001 through 3213028; 3213030 through 3213041

3213029; 3213042 through 3213103;

3246001 through 3246217; 3246219; 3246223

3246218; 3246220 through 3246222;

3246224 through 3246244

32R-8029001 through 32R-8629008;

3229001 through 3229003

32-8006002 through 32-8606023;

3206001 through 3206019; 3206042 through 3206044;

3206047; 3206050 through 3206055; 3206060

32-8024001 through 32-8424002

3257001 through 3257483

3232001 through 3232074

3255001 through 3255014; 3255026

3255015 through 3255025; 3255027; 3255051

34-E4; 34-7250001 through 34-7450220

34-7570001 through 34-8170092

34-8133001 through 34-8633031;

3433001 through 3433172; 3448001 through 3448037

3448038 through 3448079; 3447001 through 3447029

3449001 through 3449377

44-7995001 through 44-8195026

4495001 through 4495013; 4496001 through 4496251

44-8107001 through 44-8207020

**COMPLIANCE TIME:**

To coincide with next regularly scheduled maintenance event, but not to exceed the next one hundred (100) hours time in service.

**APPROVAL:**

The technical content of this Service Bulletin has been shown to comply with the applicable Federal Aviation Regulations and is FAA approved.

**PURPOSE:**

Piper has received two field reports of incorrectly-assembled control wheel shafts. Specifically, the shaft common to the sprocket and the universal joint (both pilot and copilot sides) may not have been inserted fully into the universal joint prior to match-drilling the hole for the taper pin that fastens the shaft to the universal joint. The cause of this condition is unknown. Holes mis-drilled in such a manner may appear visually to be acceptable, when in fact the hole in the shaft may be too close to the end of the shaft, causing a significant reduction in joint strength.

Left uncorrected, this condition could lead to separation of the control wheel shaft, resulting in loss of pitch and roll control.

This Service Bulletin provides instructions for a mandatory inspection of the shaft to universal joint interface to ensure that they are assembled correctly on all aircraft that might be affected.

**INSTRUCTIONS:**

1. Gain access to the forward end of the control wheel column between the instrument panel and the forward firewall.
2. Locate the shaft and the universal joint (2 per aircraft), which are fastened together with a threaded taper pin, as shown in Figures 1 and 2. These components are installed on the aft side of the T-bar assembly.

**NOTE:** Some early model aircraft may have a hex head bolt installed, instead of a taper pin. In both cases, inspection is required to verify adequate edge distance for the hole in the shaft.

**NOTE:** Each universal joint must be fastened to the mating shaft with either a taper pin or a bolt. Any other configuration does not conform to type design.

3. Inspect each universal joint for the presence of a witness hole, as shown in Figure 2. Most aircraft will have this witness hole feature. However, some early model aircraft may not have a witness hole. If no witness hole exists, proceed to step 5.
4. Insert a 3/64 inch diameter drill rod into each witness hole as far as it will go with hand pressure. Measure the depth of penetration:
  - If the drill rod penetration depth measures approximately 0.2 inches, this indicates that the drill rod is bottoming out against the near side of the fully inserted shaft. This installation is correct. Proceed to step 8.
  - If the drill rod penetration depth exceeds 0.2 inches, this indicates that the drill rod is bottoming out against the far side inner wall of the universal joint, and is not making contact with the shaft. Universal joints with this condition may have a shaft with inadequate edge distance, and will require further inspection. Proceed to step 5B.
5. Additional Inspection
  - If the inspection from step 3 identifies a universal joint without a witness hole, perform the instructions in either step 5A or step 5B, at the operator's discretion.
  - If the inspection from step 4 identifies a shaft with potentially inadequate edge distance, perform the instructions in step 5B.
  - A. Witness hole drilling procedure
    - 1) Order WITNESS HOLE DRILL FIXTURE, Piper part number 766-585.
    - 2) Temporarily remove the taper pin (or bolt, as applicable). See Figures 4 and 5, Views A and B.

**INSTRUCTIONS:** (Continued)

- 3) Temporarily pin the 766-585 WITNESS HOLE DRILL FIXTURE over the universal joint by installing the 400-453 bolt through the hole in the universal joint created by the removal of the taper pin (or bolt, as applicable), from step 5 A 2) directly above. Install 404-534 nut, finger tight. Note: 400-453 bolt and 404-534 nut are components of the 766-585 WITNESS HOLE DRILL FIXTURE. See Figure 5, View C.

**NOTE:** The 766-585 WITNESS HOLE DRILL FIXTURE should fit over the universal joint with little or no relative movement possible. If necessary, temporarily wrap masking tape around the outside of the universal joint to increase the outside diameter, and enable a snug fit prior to proceeding to step 4) below.

**WARNING:** WEAR EYE PROTECTION WHEN DRILLING.

- 4) Using a #40 drill bit (.098 inch diameter) and the 766-585 WITNESS HOLE DRILL FIXTURE for alignment, drill a witness hole in the universal joint, to a depth of .185 to .235 inches measured from the outer surface of the Universal Joint.
- 5) Remove the 766-585 WITNESS HOLE DRILL FIXTURE and Insert a 3/64 inch diameter drill rod into the newly created witness hole as far as it will go with hand pressure. Measure the depth of penetration:
  - If the drill rod penetration depth measures .235 inches or less, this indicates that the drill rod is bottoming out against the near side of the fully inserted shaft. This installation is correct. Proceed to step 8.
  - If the drill rod penetration depth exceeds .235 inches, this indicates that the drill rod is bottoming out against the far side inner wall of the universal joint, and is not making contact with the shaft. Universal joints with this condition may have a shaft with inadequate edge distance, and will require further inspection. Proceed to step 5B.

**B. Disassembly**

Temporarily remove the taper pin (or bolt, as applicable) and disassemble the universal joint from the shaft.

- If the distance from the end of the shaft to the centerline of the hole for the taper pin (or bolt) measures 0.19 inches or more, the edge distance is adequate, and existing parts may be reassembled. Proceed to step 7.
- If the distance from the end of the shaft to the centerline of the hole for the taper pin (or bolt) measures less than 0.19 inches, the edge distance is inadequate, and replacement of the shaft is required. Proceed to step 6.

6. If the inspection from step 5 identifies a shaft that must be replaced, identify and order the correct replacement shaft using Table 1, 2 or 3 as applicable.

**NOTE:** In some cases, the replacement part that is delivered to the customer may have a different part number than the one specified in Tables 1 through 3 of this Service Bulletin. Differences in part numbers may be due to special service requirements, design improvements, or changes in part number naming convention over time. Table 4 provides all part numbers that are acceptable replacements for each part number specified in Tables 1 through 3.

7. In addition, replace any universal joint that exhibits damage, corrosion or excessive wear. Mate the shaft to the universal joint using the following procedure:

**A. For installations using taper pins:**

- 1) Insert shaft into universal joint, to a depth that achieves a minimum of 0.19 inches from the end of the shaft to the centerline of the hole for the taper pin. Drill hole through mated parts at taper pin location, using a #5 (.2055 inch diameter) drill bit.
- 2) Ream drilled hole in steps, with a #1 tapered reamer, Piper P/N 906-713. In a properly sized tapered hole, the tapered pin shall install to a depth such that the small end of the tapered shank (where the threads begin) is between 0.030 inches inside and 0.062 inches outside of outer surface.

**INSTRUCTIONS:** (Continued)

## B. For installations using hex head bolts:

Insert shaft into universal joint, to a depth that achieves a minimum of 0.19 inches from the end of the shaft to the centerline of the hole for the bolt. Drill hole through mated parts at bolt location, using a #16 (.1770 inch diameter) drill bit. Ream hole to final size of .1870 to .1875 inches in diameter.

## 8. Reinstall threaded fastener

## A. For taper pins:

Install tapered pin through mated parts. (See Figure 3). Install the appropriate washer under the nut, using the following criteria:

- If pin shoulder (small taper end) does not protrude past outer surface, install an NAS1149F0363P washer (Piper P/N 690-612) under nut.
- If pin shoulder (small taper end) protrudes past tube surface, install an AN975-3 washer (Piper part number 494-093) under nut.

**NOTE:** Do not reuse the nut that installs the taper pin. Taper pins, washers, sprockets and universal joints may be reused, if they are determined to be in airworthy condition.

## B. For hex head bolts:

Install bolt, washer and nut to match original hardware stack up.

**NOTE:** Do not reuse the nut that installs the bolt. Bolts, washers, sprockets and universal joints may be reused, if they are determined to be in airworthy condition.

## 9. Make a logbook entry indicating compliance with this Service Bulletin.

**NOTE:** Taper pins may become difficult to remove on older aircraft. If necessary, contact Piper Aircraft at (772) 299-2141 for the location of a Piper authorized facility with experience in this procedure. Piper normal business hours are 7:30 AM to 4:30 PM EST, Monday through Friday.

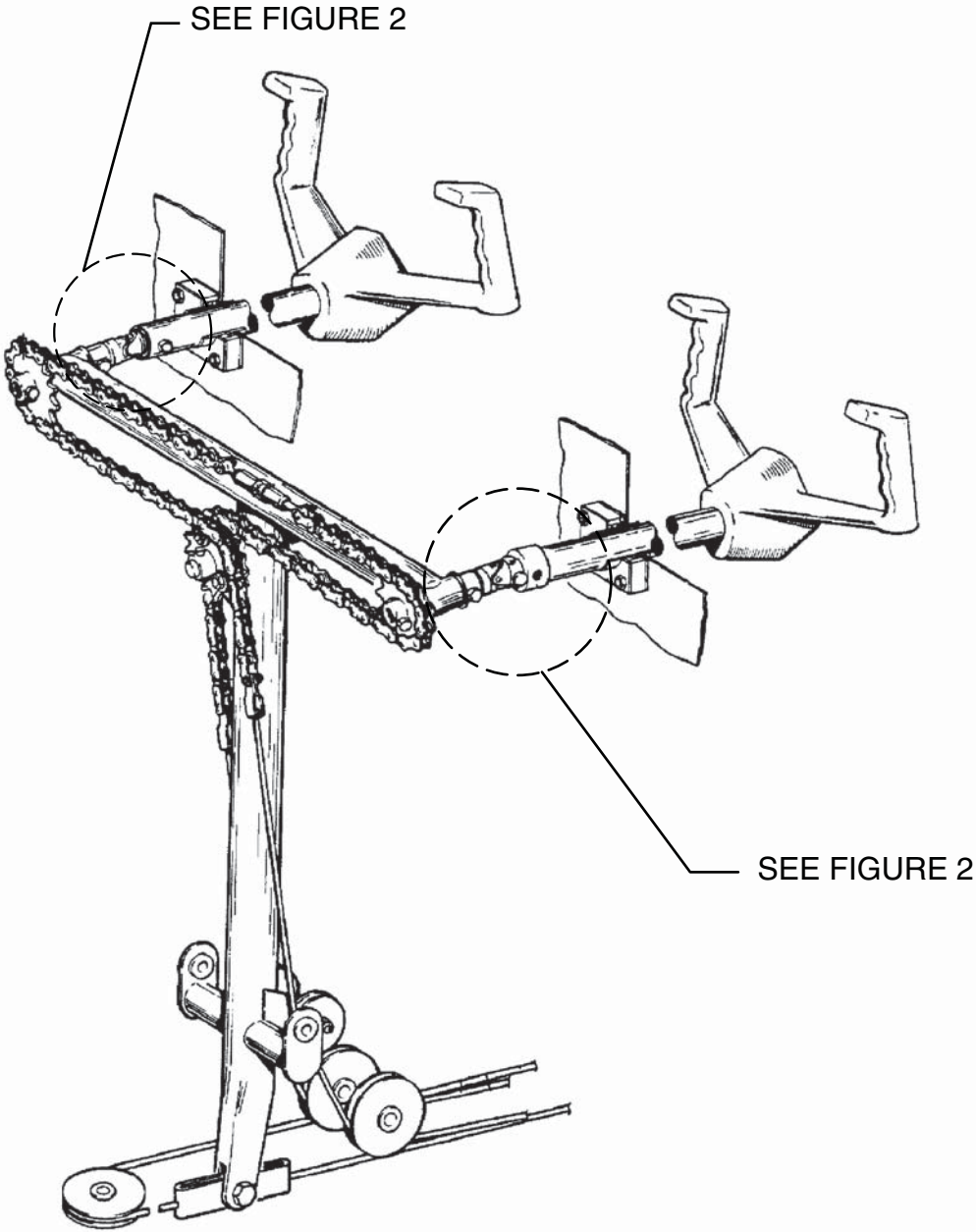

Figure 1  
Control Column Assembly

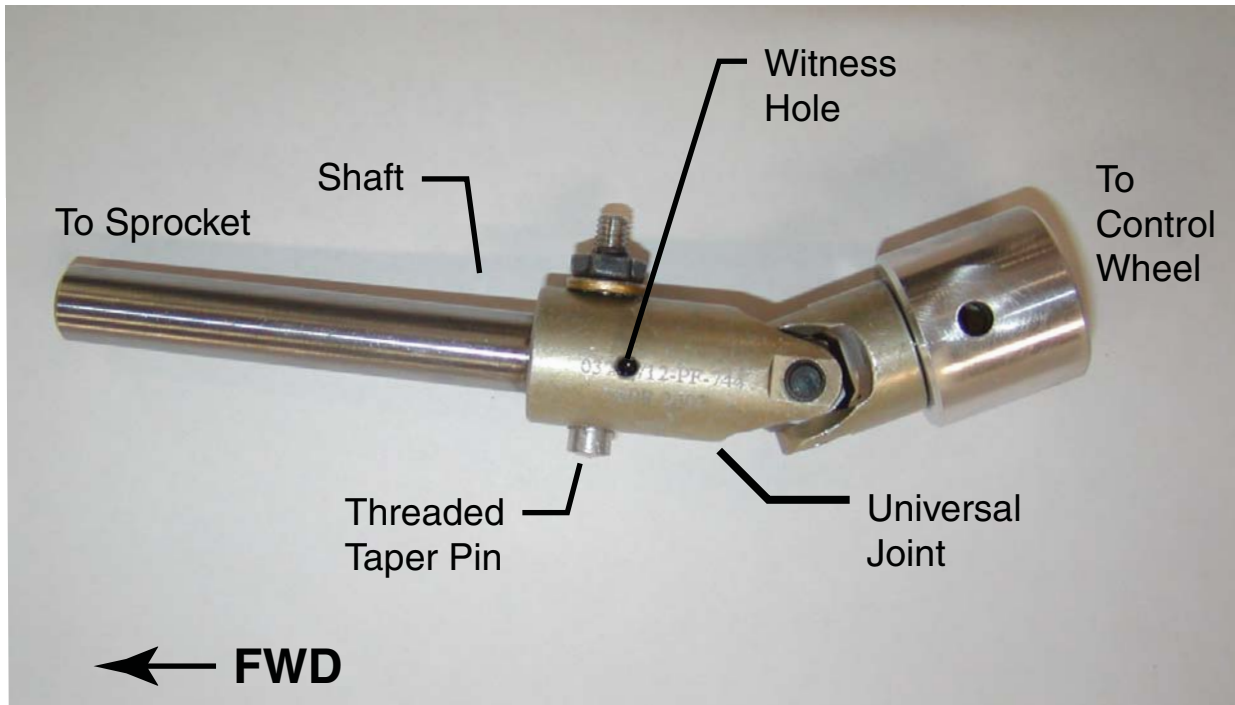

Figure 2  
Shaft Fastened to Universal Joint

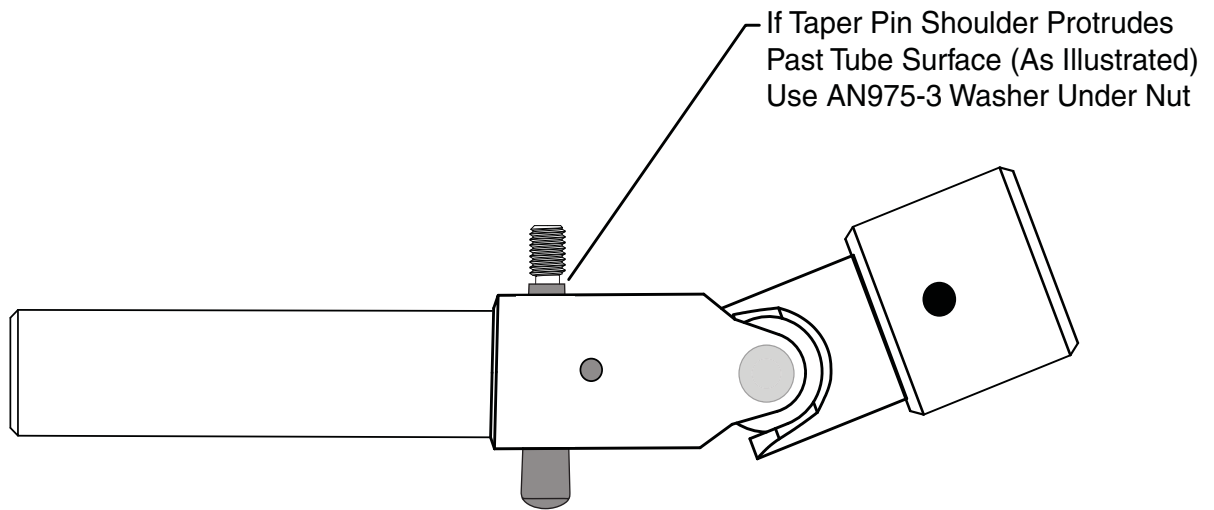

Figure 3  
Taper Pin Protrusion

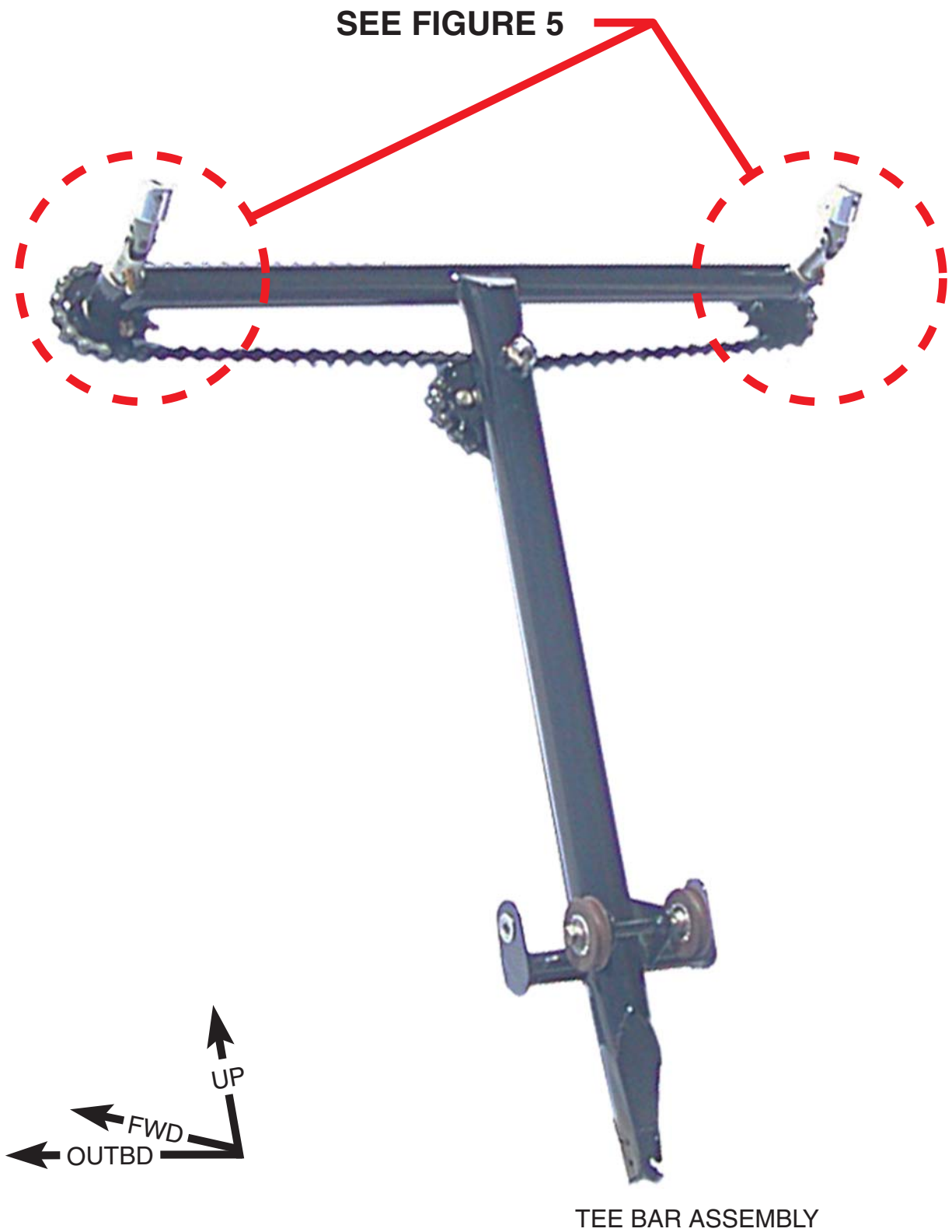
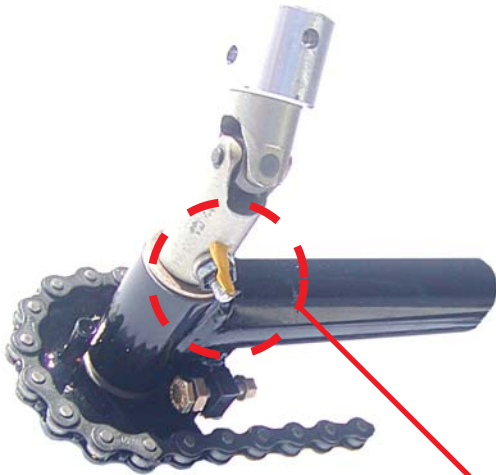

Figure 4  
Witness Hole Drilling Procedure





TAPER PIN INSTALLED  
**VIEW A**



TAPER PIN REMOVED  
**VIEW B**

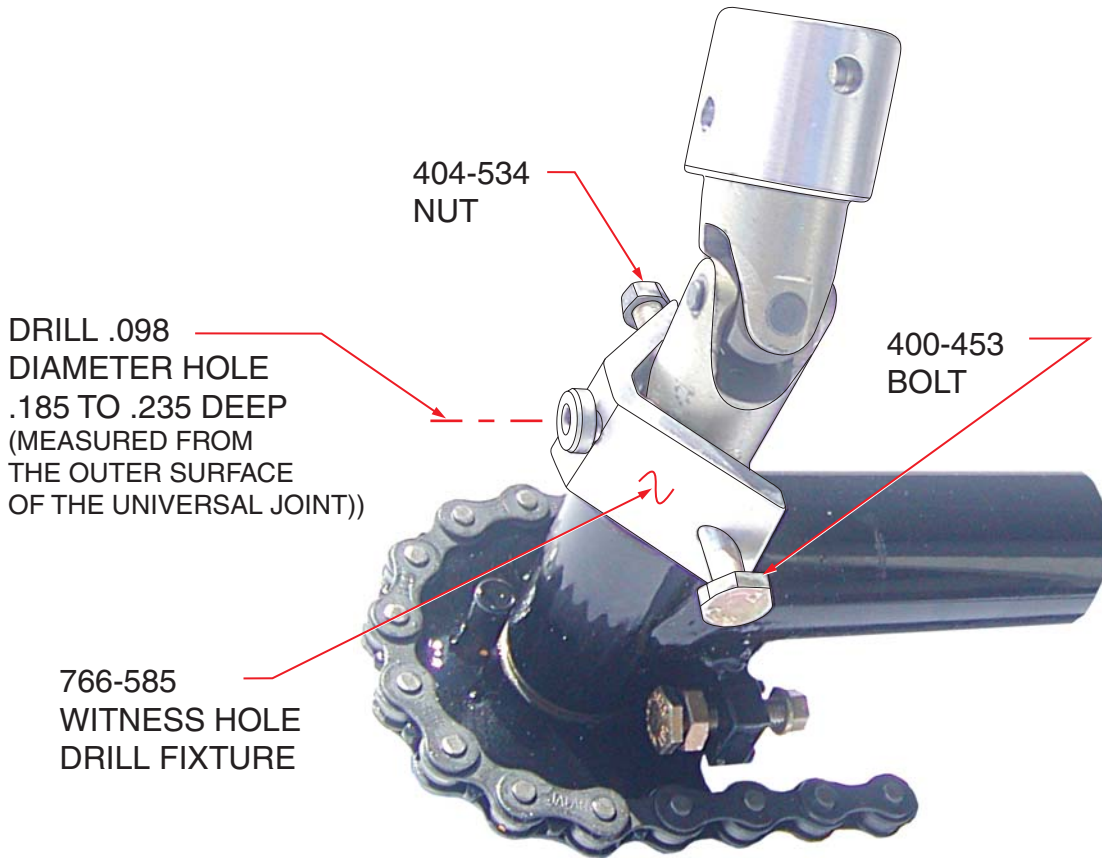

**VIEW C**

766-585 WITNESS HOLE DRILL FIXTURE PINNED IN PLACE

Figure 5  
Witness Hole Drilling Procedure

**MATERIAL REQUIRED:** The correct part numbers may be found in the applicable Aircraft Parts Catalog and Tables 1, 2 and 3.

One (1) each, Witness Hole Drill Fixture, Piper part number 766-585.  
- (Includes nut and bolt)

**AVAILABILITY OF PARTS:** Your Piper Service Facility.

**EFFECTIVITY DATE:** This Service Bulletin is effective upon receipt.

**SUMMARY:** Applicable Factory Participation is limited to new aircraft in warranty at the time of compliance. Factory Participation will remain in effect for a period of time not to exceed 180 days from the date of this Service Bulletin.

Please contact your Factory Authorized Piper Service Facility to make arrangements for compliance with this Service Bulletin in accordance with the compliance time indicated.

**NOTE:** Please notify the factory of any address/ownership corrections. Changes should include aircraft model, serial number, current owner's name and address.

Corrections and/or changes should be directed to:

PIPER AIRCRAFT, INC.  
Attn: Customer Service  
2926 Piper Drive  
Vero Beach, FL 32960

Table 1  
REPLACEMENT SHAFT and UNIVERSAL JOINT

Model	Serial Number	Shaft		Universal Joint
		left (Pilot)	right (Copilot)	
PA-28-140 Cherokee	28-20001 through 28-20160	62716-002	62716-003	62834-000
	28-20161 through 28-21845	62716-004	62716-005	62834-000
	28-21931 through 28-21934			
	28-21846 through 28-21930	62716-006	62716-007	62834-002
	28-21935 through 28-25400			
28-25401 through 28-26946	62716-007	62716-007	62834-002	
28-7125001 through 28-7725290				
PA-28-150 Cherokee	28-1 through 28-1760	62716-002	62716-003	62834-000
	28-03, 28-1760A			
	28-1761 through 28-3377	62716-004	62716-005	62834-000
	28-3378 through 28-4377	62716-006	62716-007	62834-002
PA-28-160 Cherokee	28-1 through 28-1760	62716-002	62716-003	62834-000
	28-03, 28-1760A			
	28-1761 through 28-3377	62716-004	62716-005	62834-000
	28-3378 through 28-4377	62716-006	62716-007	62834-002
PA-28-180 Cherokee	28-671 through 28-1760	62716-002	62716-003	62834-000
	28-03			
	28-1761 through 28-3377	62716-004	62716-005	62834-000
	28-3378 through 28-4377	62716-006	62716-007	62834-002
	28-4378 through 28-5859	62716-007	62716-007	62834-002
28-7105001 through 28-7205318				
PA-28S-160 Cherokee	28-1 through 28-1760	62716-002	62716-003	62834-000
	28-1760A			
PA-28S-180 Cherokee	28-671 through 28-1760	62716-002	62716-003	62834-000
	28-1761 through 28-3377	62716-004	62716-005	62834-000
	28-3378 through 28-4377	62716-006	62716-007	62834-002
	28-4378 through 28-5859	62716-007	62716-007	62834-002
	28-7105001 through 28-7105234			
PA-28-235 Cherokee	28-10001 through 28-10486	62716-002	62716-003	62834-000
	28-10487 through 28-10719	62716-004	62716-005	62834-000
	28-10720 to 28-11039	62716-006	62716-007	62834-002
	28-11040 through 28-11378	62716-007	62716-007	62834-002
	28-7110001 through 28-7210023			
28E-11				
28-7310001 through 28-7710089				
PA-28-236 Dakota	28-7911001 through 28-8611008	62716-007	62716-007	62834-002
	2811001 through 2811050			
PA-28-151 Warrior	28-7415001 through 28-7715314	62716-007	62716-007	62834-002
PA-28-161 Cadet	2841001 through 2841365	62716-007	62716-007	62834-002
PA-28-161 Warrior II	28-7716001 through 28-8216300	62716-007	62716-007	62834-002
	28-8316001 through 28-8616057			
	2816001 through 2816109			
	2816110 through 2816119			
	2842001 through 2842305			

Table 2  
REPLACEMENT SHAFT and UNIVERSAL JOINT

Model	Serial Number	Shaft		Universal Joint
		left (Pilot)	right (Copilot)	
PA-28-161 Warrior III	2816110 through 2816119 2842001 through 2842305	62716-007	62716-007	62834-002
PA-28-180 Archer	28-E13 28-7305001 through 28-7505260	62716-007	62716-007	62834-002
PA-28-181 Archer II	28-7690001 through 28-8690056 28-8690061, 28-8690062 2890001 through 2890205	62716-007	62716-007	62834-002
PA-28-181 Archer III	2890206 through 2890231 2843001 through 2843672	62716-007	62716-007	62834-002
PA-28-201T Turbo Dakota	28-7921001 through 28-7921095	62716-007	62716-007	62834-002
PA-28R-180 Arrow	28R-30002 through 28R-31270 8R-7130001 through 28R-7130013	62716-007	62716-007	62834-002
PA-28R-200 Arrow	28R-35001 through 28R-35820 28R-7135001 through 28R-7135229	62716-007	62716-007	62834-002
PA-28R-200 Arrow II	28R-7235001 through 28R-7635545	62716-007	62716-007	62834-002
PA-28R-201 Arrow III	28R-7737002 through 28R-7837317 2837001 through 2837061 2844001 through 2844138	62716-007	62716-007	62834-002
PA-28R-201T Turbo Arrow III	28R-7703001 through 28R-7803374 2803001 through 2803012	62716-007	62716-007	62834-002
PA-28RT-201 Arrow IV	28R-7918001 through 28R-7918267 28R-8018001 through 28R-8218026	62716-007	62716-007	62834-002
PA-28RT-201T Turbo Arrow IV	28R-7931001 through 28R-8631005 2831001 through 2831038	62716-007	62716-007	62834-002
PA-32-260 Cherokee Six	32-03, 32-04	62716-004	62716-005	62834-000
	32-1 through 32-600	62716-006	62716-007	62834-002
	32-601 through 32-690	62716-007	62716-007	62834-002
	32-691 through 32-1297 32-7100001 through 32-7800008	62716-007	62716-007	62834-002
PA-32-300 Cherokee Six	32-15, 32-21	62716-004	62716-005	62834-000
	32-40000 through 32-40415	62716-006	62716-007	62834-002
	32-40416 through 32-40974	62716-007	62716-007	62834-002
	32-7140001 through 32-7940290	62716-007	62716-007	62834-002
PA-32S-300 Cherokee Six Seaplane	32S-15	62716-004	62716-005	62834-000
	32S-40000 through 32S-40415	62716-006	62716-007	62834-002
	32S-40416 through 32S-40974	62716-007	62716-007	62834-002
	32S-7140001 through 32S-7240137	62716-007	62716-007	62834-002
PA-32R-300 Lance	32R-7680001 through 32R-7880068	62716-007	62716-007	62834-002
PA-32RT-300 Lance II	32R-7885002 through 32R-7985106	62716-007	62716-007	62834-002
PA-32RT-300T Turbo Lance II	32R-7787001 32R-7887002 through 32R-7987126	62716-007	62716-007	62834-002

Table 3  
REPLACEMENT SHAFT and UNIVERSAL JOINT

Model	Serial Number	Shaft		Universal Joint
		left (Pilot)	right (Copilot)	
PA-32R-301 Saratoga SP	32R-8013001 through 32R-8613006 3213001 through 3213028 3213030 through 3213041	62716-007	62716-007	62834-002
PA-32R-301 Saratoga II HP	3213029 3213042 through 3213103 3246001 through 3246217 3246219; 3246223	62716-007	62716-007	62834-002
PA-32R-301 Saratoga II HP (with Entegra)	3246218 3246220 through 3246222 3246224 through 3246244	62716-007	62716-007	62834-002
PA-32R-301T Turbo Saratoga SP	32R-8029001 through 32R-8629008 3229001 through 3229003	62716-007	62716-007	62834-002
PA-32-301 Saratoga	32-8006002 through 32-8606023 3206001 through 3206019 3206042 through 3206044 3206047 3206050 through 3206055 3206060	62716-007	62716-007	62834-002
PA-32-301T Turbo Saratoga	32-8024001 through 32-8424002	62716-007	62716-007	62834-002
PA-32R-301T Saratoga II TC	3257001 through 3257483	62716-007	62716-007	62834-002
PA-32-301FT Piper 6X	3232001 through 3232074	62716-007	62716-007	62834-002
PA-32-301XTC Piper 6XT	3255001 through 3255014 3255026	62716-007	62716-007	62834-002
PA-32-301XTC Piper 6XT (with Entegra)	3255015 through 3255025 3255027, 3255051	62716-007	62716-007	62834-002
PA-34-200 Seneca	34-E4 34-7250001 through 34-7450220	62716-007	62716-007	62834-002
PA-34-200T Seneca II	34-7570001 through 34-8170092	62716-007	62716-007	62834-002
PA-34-220T Seneca III	34-8133001 through 34-8633031 3433001 through 3433172 3448001 through 3448037	62716-007	62716-007	62834-002
PA-34-220T Seneca IV	3448038 through 3448079 3447001 through 3447029	62716-007	62716-007	62834-002
PA-34-220T Seneca V	3449001 through 3449377	62716-007	62716-007	62834-002
PA-44-180 Seminole	44-7995001 through 44-8195026 4495001 through 4495013 4496001 through 4496251	62716-007	62716-007	62834-002
PA-44-180T Seminole	44-8107001 through 44-8207020	62716-007	62716-007	62834-002

Table 4  
ACCEPTABLE REPLACEMENT SHAFT and UNIVERSAL JOINT PART NUMBERS

Piper Part Number (as stated in Table 1)	Acceptable Replacement Part Numbers
62716-002	62716-2 62716-02
62716-003	62716-3 62716-03 62716-7 62716-07 62716-007
62716-004	62716-4 62716-04
62716-005	62716-5 62716-05 62716-7 62716-07 62716-007
62716-006	62716-6 62716-06
62716-007	62716-7 62716-07
62834-000	62834 62834-0 62834-00
62834-002	62834-2 62834-02 62834-802